



A VLF Comparator for Relating Local Frequency to U.S. Standards

Comparing phase changes between a local standard and standard VLF broadcasts permits fast, precise frequency calibration traceable to NBS

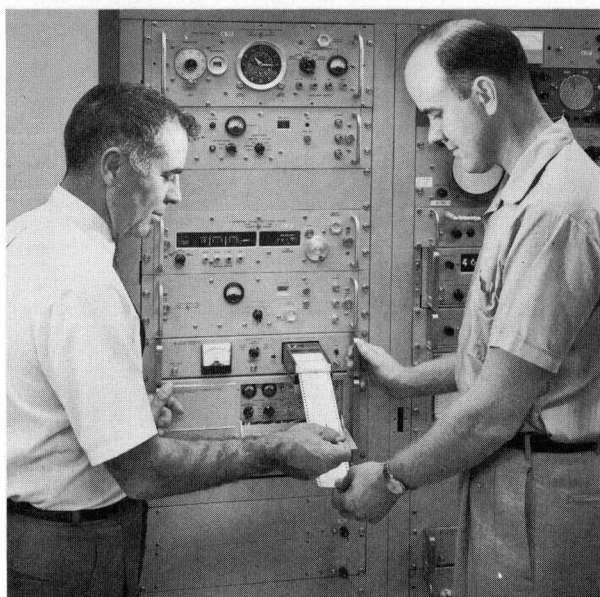

Fig. 1. VLF Phase Comparator calibrates local frequency standard with respect to national standards by making time plot of phase difference between WWVB standard broadcast carrier and locally-generated signal. Project Leader Dexter Hartke (left) and -hp- Standards Engineer James A. Marshall examine phase/time plot produced by Comparator.

SEE ALSO:
Tunable VLF Comparator, p. 8

Fig. 2. Typical recording made by VLF Comparator showing comparison between electronic counter time base oscillator and WWVB. Horizontal scale is 1 hr. per major division, vertical scale is $\frac{1}{3}$ μ sec per minor division. Slope of trace shows phase change of 1 μ sec between 9:00 A.M. and 12:00 N., equivalent to frequency offset of 1 part in 10^{10} . Change in slope after 12:00 N. represents oscillator drift. Periodic "pulses" result from once-an-hour 45° phase shift provided in WWVB carrier for identification.

THE REMARKABLE improvements made in frequency control during the last decade have necessitated commensurate improvements in the art of frequency calibration. Such improvements have been made possible by the transmission of phase-stable low-frequency radio waves by the National Bureau of Standards on stations WWVB (60 kc) and WWVL (20 kc). These transmissions are capable of yielding comparison precisions as high as a few parts in 10^{12} within the continental U.S.

Establishment of the NBS low-frequency standard broadcasts suggested the possibility of a simplified comparator system for relating local frequency standards to the U.S. Frequency Standard. Such a system has recently been designed in the form of a VLF Comparator for use with WWVB. This is a simplified system intended for calibrating high quality frequency standards or for monitoring atomic frequency standards with respect to the United States Frequency Standard.

The essential function of the VLF Comparator is to make accurate measurements of the phase difference between the 60 kc WWVB carrier and a stable local frequency. The phase difference measured in microseconds is automatically plotted

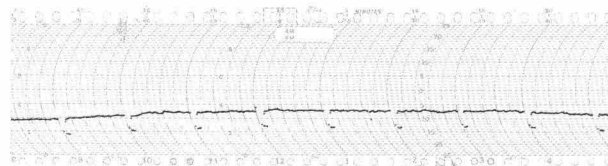

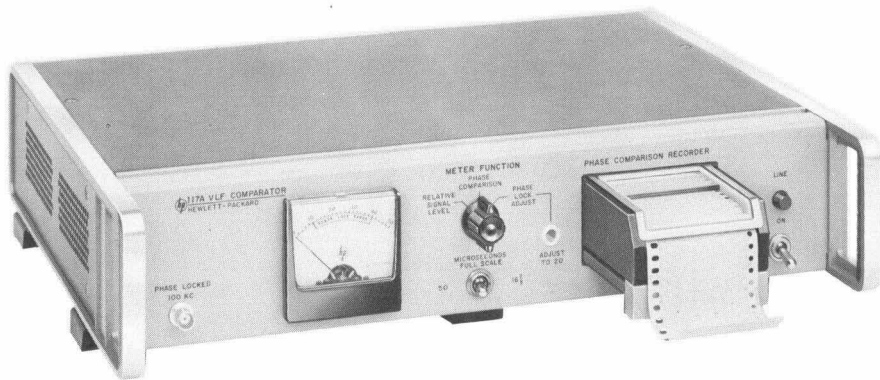

Fig. 3. Hewlett-Packard Model 117A VLF Phase Comparator.

on a built-in strip-chart recorder, providing a record of the frequency offset of the local standard oscillator as shown by the typical record of Fig. 2. The trace is easily evaluated with transparent templates, supplied with the instrument, that relate the slope of the recorder trace to the frequency offset (see Fig. 6). Comparison accuracies of better than 1 part in 10^{11} have been achieved with the system.

The VLF Comparator is a complete system (exclusive of local standard) which consists in one package of a receiver, an electronic servo-controlled oscillator which functions as a narrow-band tracking filter, a linear phase comparator, and a strip chart recorder, all shown in the simplified block diagram of Fig. 4. A loop antenna and 100 feet of lead-in cable are included with the system.

SYSTEM DETAILS

A more detailed block diagram of the Comparator is shown in Fig. 5. The

phase comparison actually is made between the local standard and a servo-controlled crystal oscillator, which serves as a tracking filter for the received WWVB 60-kc carrier. The recorder plots the results of the phase comparison with a resolution of better than $1 \mu\text{sec}$ phase difference to show

the frequency offset of the local frequency standard.

As a tracking filter, the servo-controlled oscillator averages and smooths any short-term variations in the received WWVB signal. The oscillator frequency is locked to the received signal by a phase detector which controls a voltage-variable capacitor in the oscillator tuning circuit. The oscillator output is compared in phase to the received 60-kc signal after transformation from 100 kc to 60 kc by a 5-to-1 divider and a $\times 3$ multiplier.

The output of the servo-controlled oscillator itself may be used as a frequency standard, although there are occasional ionospheric effects that affect the phase stability of the received LF radio signal and may reduce the stability of the servo-controlled oscillator to a few parts in 10^9 .

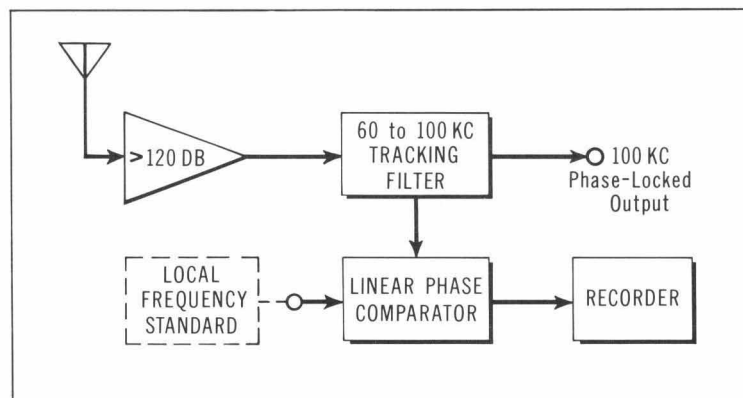

Fig. 4. Simplified diagram of -hp- Model 117A VLF Comparator System. Recorder makes time plot of phase difference between local frequency standard and received standard broadcast carrier.

FREQUENCY CALIBRATION USING LF STANDARD BROADCASTS

Low frequency standard broadcasts now provided by the National Bureau of Standards permit precise calibration of local frequency standards in a relatively short time. High accuracy is possible with these broadcasts because LF waves propagate principally as ground waves and thus have high phase stability at the receiver.

Precision frequency comparisons can be made by measuring changes in phase over a period of time between the cycles of a locally-derived signal and those of a low-frequency standard broadcast carrier. The frequency offset of the locally-generated signal with re-

spect to the transmitted carrier then is equivalent to the rate of change in the phase difference (measured as a time interval); i.e.,

$$\Delta t/T = \Delta f/f.$$

The VLF Comparator described in this article makes precise phase comparisons between a 60-kc signal derived from a local frequency standard and the 60-kc carrier of the NBS standard frequency station WWVB. The instrument records the phase difference as a function of time on a self-contained strip-chart recorder and under laboratory conditions the resolution of the

recording is better than $1 \mu\text{sec}$ of phase difference. The recording is easily interpreted to show the offset of the local frequency standard with respect to the transmitted standard frequency.

Comparisons made with this instrument over ten-day periods can yield accuracies of parts in 10^{12} provided, of course, that the local standard is of commensurate quality. Comparison accuracies of parts in 10^{10} can be achieved easily in a comparison period of about an hour during times of low ionospheric activity, as commonly found during daylight hours. (See also a discussion of a tunable VLF Comparator on page 8.)

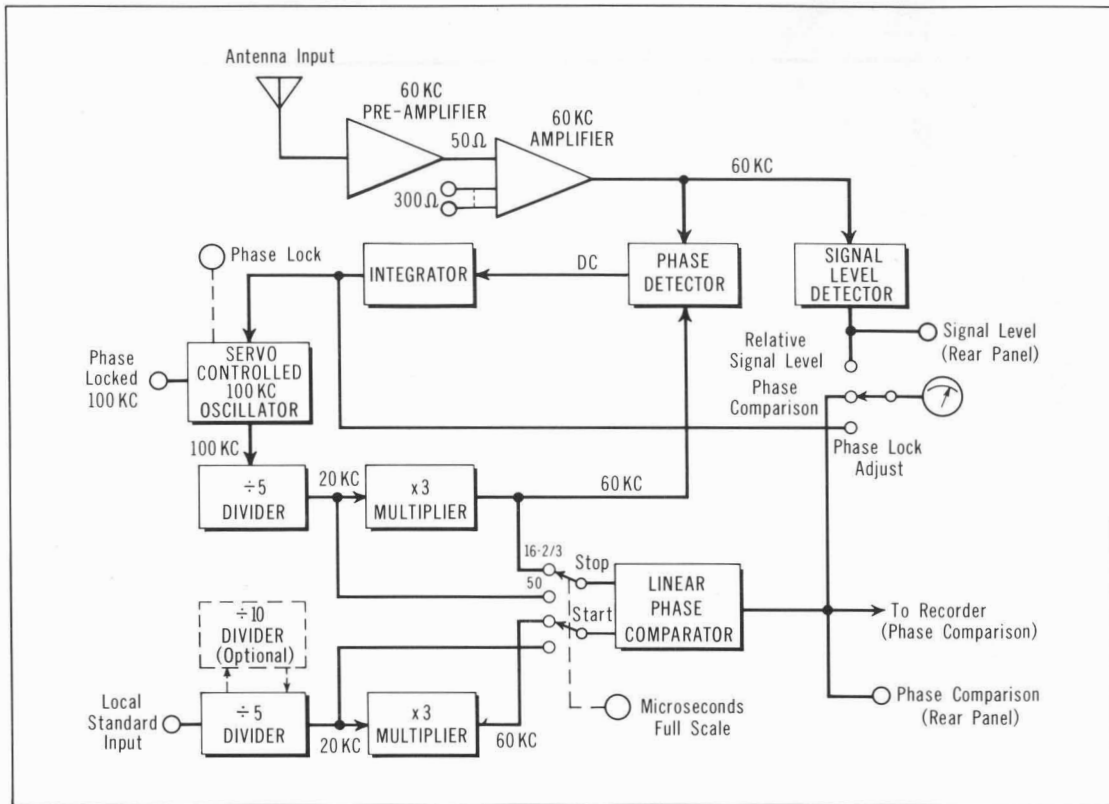

Fig. 5. Block diagram of VLF Comparator System.

The local standard 100-kc frequency* is compared to the crystal oscillator signal in the linear phase comparator after division by 5 and multiplication by 3 to 60 kc. The phase comparison thus can be made at 60 kc, for a full scale 360° phase difference of $16\frac{2}{3}$ μ sec, or it can be made at 20 kc to provide a full scale phase difference

* A 10-to-1 divider that permits use of the Comparator with a 1-Mc standard has been designed as a plug-in option.

of 50 μ sec. A front panel switch selects the desired scale.

LINEAR PHASE COMPARATOR

The linear phase comparator is a flip-flop that is turned on once a cycle by the local standard signal and turned off again by the phase-locked oscillator signal, as shown in Fig. 9. This action generates a constant-amplitude rectangular pulse train that has a repetition rate equal to the comparison

frequency and a pulse width that is determined by the relative phase difference between the local standard and WWVB. This type of comparator has an output current that varies linearly with respect to phase difference.

The output of the linear comparator is applied to the recorder and also to two rear panel connectors, one for use with galvanometric recorders and one for potentiometric recorders. The comparator output is also applied to the front panel meter when the *Function* switch is in the *Phase Comparison* position.

RECORDER

The strip chart recorder is a sampling device that makes a dot on pressure-sensitive paper once every sixty seconds. The chart speed is 1 inch/hour so that the trace resembles a continuous line when the trace is of moderate slope.

LOOP ANTENNA

The standard antenna included with the system is a 43-inch diameter loop housed in heavy aluminum tubing at-

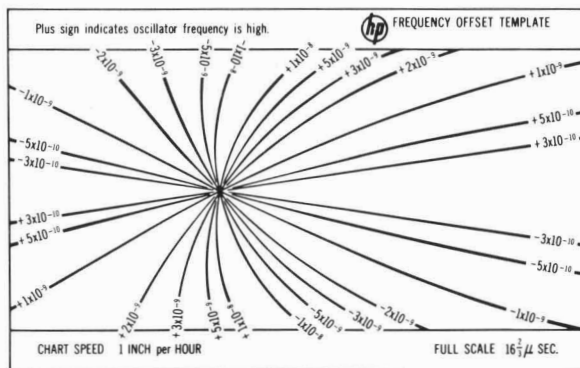

Fig. 6. Transparent template simplifies reading of recorder trace. Template relates slope of trace to frequency offset between local and WWVB signals. Template shown here is for use with $16\frac{2}{3}$ μ sec scale (phase difference in microseconds across width of recording). Similar templates are used with 50 μ sec scale.

tached to a cast-aluminum box (Fig. 10). The antenna loop wires are secured by foamed-in-place polyurethane inside the tubing, and a pre-amplifier is mounted on the waterproof box cover.

The effective electrical height of the antenna is approximately 1.6 centimeters which, when multiplied by a field strength of only 60 microvolts per meter, delivers about 1 microvolt of signal to the 117A, a signal level adequate for satisfactory operation (the field strength at receiver sites within the continental United States usually amounts to hundreds of microvolts per meter). Although no attempt is made to keep the null in the figure-8 field pattern free of quadrature contamination, there may be cases where orienting the antenna can reduce the effect of man-made interference without seriously affecting the level of the desired signal.

A push-pull amplifier using two Nuvistor triodes serves as an active coupler between the high impedance resonant loop and a magnetostrictive filter which drives the output terminals. The Nuvistors, operated at greatly reduced voltages for long life expectancy, have extremely linear characteristics in the range of voltages encountered.

The magnetostrictive filter, which has a bandwidth of only 30 cps, minimizes the possibility of blocking of the input amplifiers by powerful transmitters on nearby channels (extensive field testing at -hp- showed that this does happen with a wideband system). The small temperature-dependent phase shift introduced by the filter has been

found to be negligible during usually-encountered temperature variations.

The lead-in carries the signal to the instrument and the operating DC power to the antenna, typically 60 milliamps at 35 v DC. A 50-ohm cable of any length from fifty to more than a thousand feet may be used as a lead-in. A balanced 300-ohm input is available for those who may wish to use other types of antennas for experiments.

RECEIVER CIRCUITS

The carrier amplifier at the input to the Comparator uses three Nuvistor tetrode stages synchronously tuned with a bandwidth of 2 kc and a gain of more than 120 db. Here again, voltages are kept low for long life expect-

ancy. Neither a manual nor an automatic gain control was found necessary or even useful since the circuitry is phase-stable for signal level changes much greater than those experienced in practice.

A simple signal-level detector provides an uncalibrated indication of the presence of the carrier and also shows if fading occurs. The signal level can be monitored by the front panel meter or by an external recorder through a telephone jack provided on the rear panel.

THE TRACKING FILTER

When NBS announced plans for higher power transmission from WWVB (and WWVL), it was proposed that a servo-controlled oscillator having an integration time of 1 to 2 seconds and a bandwidth of about 1 cps would be adequate as a tracking filter for continental U. S. reception, provided that the LF or VLF carriers were continuously transmitted. The use of such a tracking filter makes the system an automatically-tuned receiver with a passband of less than 1 cps, a highly desirable feature for discriminating against the high noise levels encountered at LF and VLF frequencies. Reliable operation of this system has been verified by an extensive field-testing program.

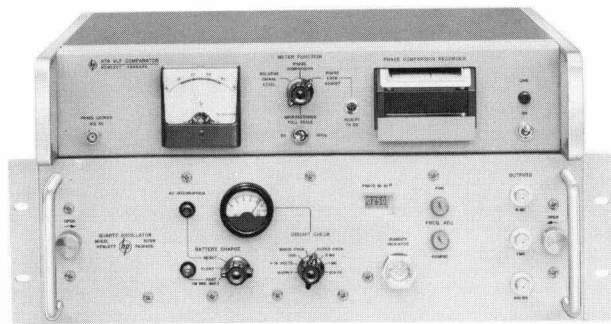

Fig. 7. Link between house frequency standards and national standards is provided by VLF Comparator (top) shown here with -hp- Model 107BR Quartz Oscillator.

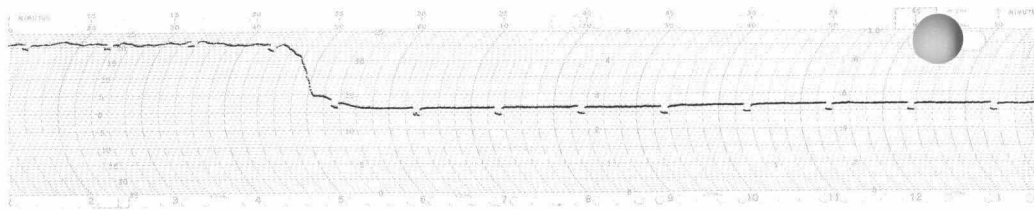

Fig. 8. Performance of VLF Comparator is shown by phase comparison made between "atomic" frequency standard (-hp- Model 5060A Cesium Beam Frequency Standard) and WWVB at Palo Alto, Calif. (900-mile path). Recorder scale is 50 μ sec edge to edge. Steady trace

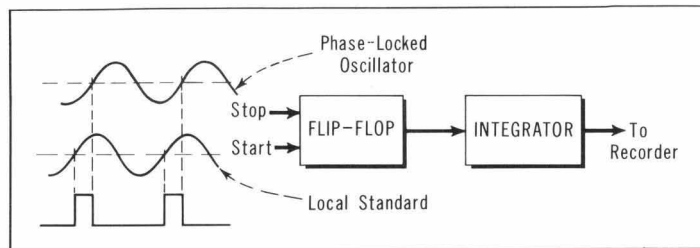
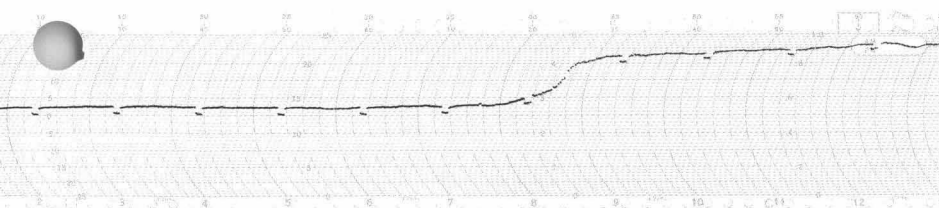

Fig. 9. Linear phase comparator generates rectangular pulses at 60 kc which are integrated to provide dc signal for operation of recorder. Pulse width, and thus dc output, is proportional to phase difference between local standard and internal phase-locked oscillator.



between 5:30 A.M. and 8:00 P.M. while entire propagation path is in daylight shows high stability of daylight signal. Comparisons are not usually made at night because of ionosphere changes which affect phase of received signal, as shown by 20- μ sec shifts at sunrise and sunset.

The tracking filter is shown in Fig. 11. It is well known that a very narrow-band tracking filter can be realized with this type of phase-locked oscillator. The integrator in the feedback loop creates a second-order system that has no significant *phase* error in the steady state and has the outstanding advantage that it can be made with simple resistive and capacitive components. The operational amplifier function is easily fulfilled by a single high- μ Nuvistor, five resistors, and a capacitor. Temperature variations cannot change the values of these components in such a way as to cause the center frequency to shift significantly.

The output of the phase detector is zero volts only when the 60-kc voltages are exactly the same frequency and 90° apart in phase. Any phase deviation causes an output which is integrated by the operational amplifier and applied to the voltage-controlled oscillator in the proper direction to restore the 90° phase relation between the 60-kc phase detector inputs.

The quartz crystal is a room-temperature NT-cut requiring no warm-up, which allows the Comparator to start making phase records in just a few minutes after turn-on. The degree of crystal frequency pulling due to servo

control can be seen on the panel meter when the *Function* switch is in the *Phase Lock Adjust* position, which shows the voltage output of the phase detector. A reading of 20 on the 0-50 scale indicates that the free-running crystal frequency is tracking WWVB with little or no servo pulling. Any reading in the "green" area between 10 and 40, however, provides phase tracking with no detectable phase error.

The transient response of the tracking filter is shown in Fig. 12. This is a plot of the voltage at the voltage-controlled reactance in response to a step change in the oscillator tuning capacitance. The overall time constant of the response (10% to 90% of final) is about 1 second.

VLF RECEPTION

The received phase-stability of VLF radio waves is affected by the ionosphere. When the effective ionosphere height and electron density profile remain constant, as is usually the case during the time that the entire propagation path is in daylight, the apparent received phase-stability and field intensity are correspondingly constant.

Occasionally, daytime ionosphere activity does occur and must be rec-

ognized for proper evaluation of the data records. If fading during daylight should occur, it is a certain indication that ionosphere disturbances are taking place and these are likely to be accompanied by apparent received phase-instabilities. The maximum error attributable to ionosphere disturbances experienced at Palo Alto on WWVB has been about 1×10^{-9} , which occurred during November, 1963. Records made at Hewlett-Packard Company in Palo Alto, however, show that days of unstable ionospheric conditions are in the minority and that one can expect to be able to work in the range between 1×10^{-10} and 1×10^{-11} most of the time. Where intercontinental phase comparisons are concerned, on the other hand, it is questionable whether comparisons accuracies of better than 1 part in 10^{10} can be achieved since the propagation path seldom is totally in daylight.

Another helpful method of determining accuracy depends upon a fairly good knowledge of the behavior of one's own local standard. The nature of aging quartz standards and of ionosphere phase anomalies are sufficiently unlike to be distinguishable. Once the aging rate of the local standard has been determined, it can be removed from the phase records with reasonable accuracy.

Discontinuities in the recorded phase difference that can result from signal or power interruptions are shown in Table 1. Usually, there is no good reason to make records overnight

TABLE 1. INCREMENTAL PHASE JUMPS (IN MICROSECONDS) POSSIBLE FOLLOWING A TEMPORARY INTERRUPTION IN SIGNALS OR POWER.

Scale Calibration	Interrupted Signal		Interrupted AC Power		Interrupted Local Std.	
	WWVB	WWVL*	WWVB	WWVL	WWVB	WWVL
50 μ sec	16- $\frac{2}{3}$	No change	10	10	3- $\frac{1}{3}$	10
16- $\frac{2}{3}$ μ sec	No change	—	3- $\frac{1}{3}$	—	3- $\frac{1}{3}$	—
10 μ sec	—	No change	—	No change	—	No change

* A VLF Comparator modified for use with WWVL at 20 kc is available, although the 20-kc transmissions are still considered to be on an experimental basis.



Fig. 10. Weatherproof antenna used with Comparator System.

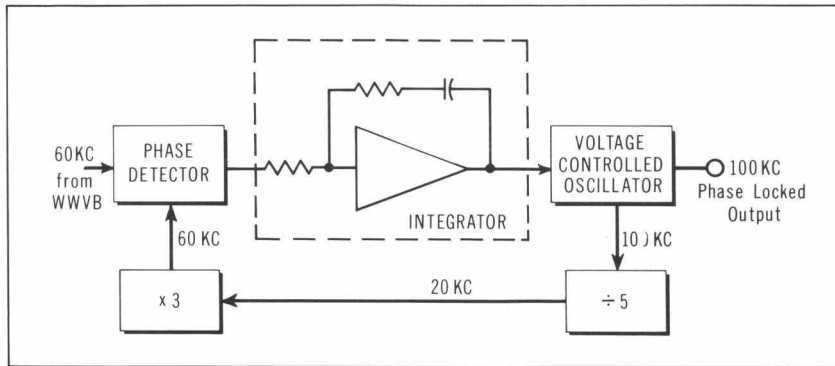

Fig. 11. Tracking filter is formed by phase-lock loop with integrator in feedback loop.

for calibrating local standards since the phase stability of WWVB in daylight hours is much better than it is between dusk and dawn. The exception occurs when one wishes to collect continuous data over many days in order to achieve a precision greater than that obtainable in a single working day. In this case, the Comparator should not be turned off nor should the local standard be disconnected.

If one attempts to make coherent records against WWVB over many days time, it is likely that the phenomenon of an integral number of advancing or retarding full 360 degree phase shifts may be recorded. Full cycle phase rotations during diurnal phase shifts have been noted by many observers at many frequencies. A 360° phase shift at 60 kc moves the recorder trace $16\frac{2}{3}$ μ sec, which would appear as a loss of coherence on the 50- μ sec scale. The obvious way to avoid this is to use the $16\frac{2}{3}$ - μ sec calibration when making measurements for periods of time longer than one working day. The fact that such phase shifts take place certainly creates a problem for any kind of timing or accumulating system which attempts to use the VLF radio wave itself, instead of a carefully-maintained local standard.

TYPICAL PERFORMANCE

As an example of what can be accomplished in a few days of intermittent broadcasting, Fig. 14 shows the phase record of a Hewlett-Packard Model 107AR Quartz Oscillator made by a VLF Comparator at the IEEE Convention in the New York Coliseum

during March, 1964. The Quartz Oscillator was turned on about noon of March 20 and at noon March 21 the frequency error was read as $+4 \times 10^{-8}$ with the frequency offset template. A coarse correction was made. At 1:30 p.m. the frequency offset was again measured and corrected by 3×10^{-9} . A final correction was made at 5:00 p.m. Similar corrections were made during the next four days (WWVB was broadcasting six hours a day at the time and was off the air completely on March 24). The correction made at noon of March 25 brought the Quartz Oscillator to within 1×10^{-10} of the USFS after only four days of intermittent broadcasting, a truly remarkable performance when one recalls the months of effort required to approach this precision by means of HF time signals.

The very high comparison accuracy possible with this VLF comparison sys-

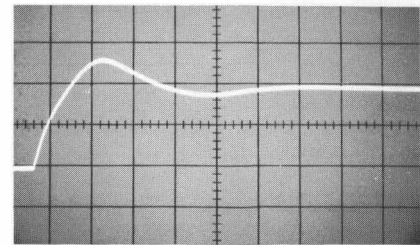

Fig. 12. Response of phase-lock loop to simulated step change in oscillator frequency. Oscilloscope sweep speed is 2 sec/cm.

tem was demonstrated by a several-day test in which an -hp- Model 5060A Cesium Beam Frequency Standard was compared with WWVB. The test thus provided a comparison of two very high stability frequency sources to show the capability of the VLF comparison technique. Corrections from NBS were applied and the following results obtained:

	5060A Offset vs WWVB	5060A Offset vs WWVL	Disagree- ment
8 days	$+4 \times 10^{-12}$	$+6 \times 10^{-12}$	$+2 \times 10^{-12}$
12 days	$+4.35 \times 10^{-12}$	$+5.6 \times 10^{-12}$	$+1.25 \times 10^{-12}$

The period of measurement was from 5-13-64 to 5-25-64.

READING THE CHART

The templates (Fig. 6) supplied with each Comparator enable interpretation of the slope of the recorded trace in terms of frequency offset of the local standard. When the frequency offset is less than that conveniently measured with the template, it can easily be calculated using the fact that there are close to 10^{10} microseconds in a 3-hour

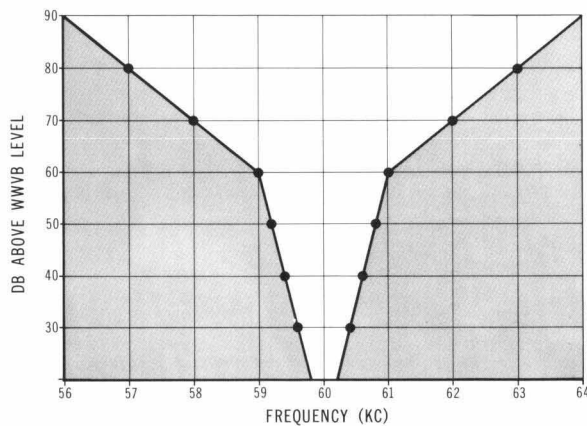

Fig. 13. Interference rejection of -hp- Model 117A VLF Comparator. Ordinate represents power level of interfering signal in db above WWVB received signal level. Interference having frequency and amplitude in shaded areas has no effect on operation of VLF Comparator.

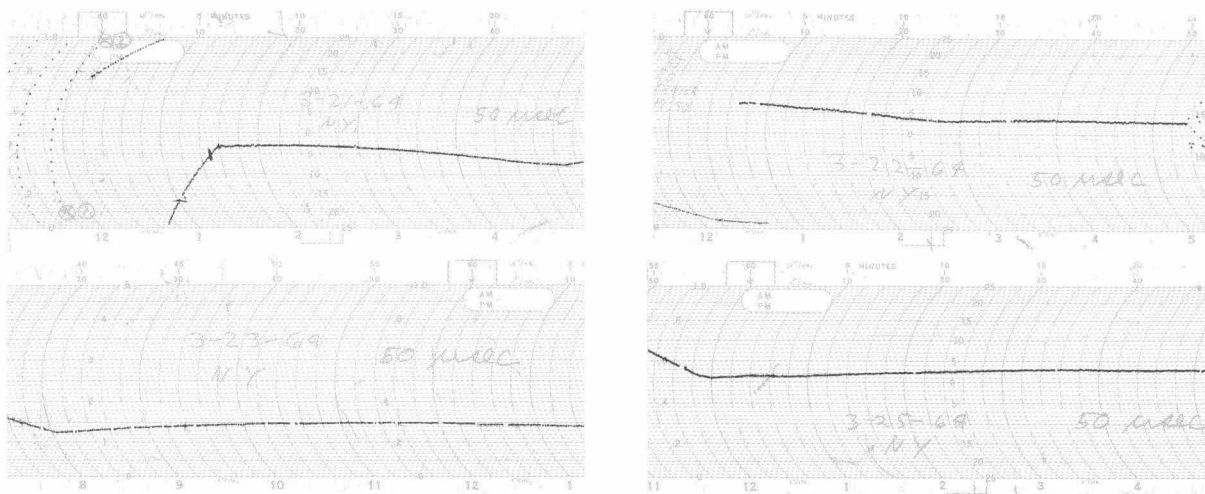

Fig. 14. Records made while putting frequency standard into operation (see text).

period. The error N in parts of 10^{10} is then:

$$\frac{N}{10^{10}} = \frac{N \text{ microseconds}}{3 \text{ hours}} = \frac{\Delta t}{T}$$

The fractional time error thus determined is, of course, the same as the fractional frequency error

$$\frac{\Delta t}{T} = \frac{\Delta f}{f}$$

The slope of the phase recording is the frequency difference between the two input frequencies, since its dimensions are $d\phi/dt$. The derivative of the slope of the phase recording is frequency drift and under conditions of stable propagation can be attributed to the local standard.

For larger frequency offsets, in the range of a few parts in 10^7 to a few parts in 10^9 , the time between recorded dots on the microsecond scale is useful for accurate fractional frequency error calculations. The following example illustrates:

Referring to the first hour of the New York IEEE Convention record of March 21, 1964 (Fig. 14), the average time between dots just before 12:00 noon was determined to be $2.45 \mu\text{sec}$ per minute (from $x1$ to $x2$ is $44 \mu\text{sec}$ in 18 minutes); this very simply yields:

$$2.45 / (60 \times 10^6) = 4.1 \times 10^{-8},$$

the actual frequency offset.

Unless enough dots are made to positively define a readable slope, it is better to measure the beat frequency by counting cycles of the front panel meter for a measured period of time while the *Meter Function* switch is set to *Phase Comparison*.

ACKNOWLEDGMENTS

A major part of the design was performed by J. M. Brawn, Jr., who also compiled much of the field test data. Many helpful suggestions were provided by Leonard S. Cutler.

—Dexter Hartke

DESIGN LEADER



DEXTER HARTKE

Dexter Hartke joined Hewlett-Packard in 1950 following graduation (BSEE) from the University of California where he was a member of Tau Beta Pi and

Eta Kappa Nu. At -hp- he has had a long association with frequency and time measuring instruments, beginning with the -hp- Models 512A and 512B heterodyne frequency converters for the 524A 10-Mc Counter, and the later plug-in versions for the 524B/C/D and 5245L Counters. He also worked on the 524B Counter and the 218A Digital Delay Generator and was Project Leader for the 540A/B Transfer Oscillators. Since 1958 he has been concerned exclusively with frequency and time calibrating equipment, being responsible for the 113A and 115A/B/C Frequency Divider and Clocks, the 724A/B and 725B Standby Power Supplies, and now the 117A VLF Comparator.

SPECIFICATIONS

-hp-

MODEL 117A

VLF COMPARATOR

- INPUT FREQUENCY:** 60 kc (WWVB Carrier).
- SENSITIVITY:** $1 \mu\text{v}$ rms into 50Ω (adequate for daylight reception anywhere in continental U. S.).
- LOCAL STANDARD INPUT:** 100 kc, 1 v rms into $1 \text{ k}\Omega$ (additional divider to accept 1 Mc available at extra cost).
- 100-kc PHASE-LOCKED OUTPUT:** 5-volt positive rectangular pulses into $5 \text{ k}\Omega$.
- RECORDER OUTPUTS:** Phase Comparison and Relative Signal Strength: 0-1 ma dc into 1400Ω and 0-100 mv dc from 2000 Ω .
- OVER-ALL PHASE STABILITY:** $\pm 1 \mu\text{sec}$ 0-50°C.
- CHART WIDTH:** 50 μsec or $16\frac{2}{3} \mu\text{sec}$, selected by front panel switch.
- CHART SPEED:** 1 inch/hour (6 and 12 inches/hour available upon request).
- METER READINGS:** Three switch positions: 1. Relative signal level. 2. Phase comparison; calibrated scales 0-50 μs full scale and 0-16 $\frac{2}{3} \mu\text{s}$ full scale. 3. Phase lock; indicated range insures negligible phase error in phase-locked oscillator.
- ADJUSTMENTS:** Front panel screwdriver control adjusts free-running frequency of voltage-controlled oscillator to compensate for crystal aging and to achieve optimum phase lock over temperature range 0-50°C. Three adjustments on rear panel make full scale calibration adjustment of internal recorder, internal meter, and external galvanometer recorder for phase comparison.
- DIMENSIONS:** Nominally 3 $\frac{1}{2}$ inches high, 16 $\frac{3}{4}$ inches wide, 11 $\frac{1}{4}$ inches deep behind front panel.
- WEIGHT:**
 - 117A: 20 lbs. (9.1 kg) net.
 - 22 lbs. (10 kg) shipping.
 - Antenna: 12.5 lbs. (5.7 kg) net.
 - 21 lbs. (9.5 kg) shipping.
- POWER:** 115 or 230 volts $\pm 10\%$, 60 cycles, 40 watts.
- STORAGE TEMPERATURE:** -50° to $+75^\circ\text{C}$.
- OPERATING TEMPERATURE:** 0-50°C.
- ACCESSORIES (included):**
 - CHART RECORDER: Amprobe Model DB81 (mounted in Comparator).
 - LOOP ANTENNA (-hp- 10509A): Antenna is 43 inches (109 cm) in diameter and mounts on 1-inch pipe thread. Operating temperature: -60° to $+80^\circ\text{C}$.
 - COAXIAL LEAD-IN CABLE (-hp- 10512A): 50-ohm, BNC-BNC connectors, 100 feet (30.5 m) long.
- PRICE:** -hp- 117A with 10509A antenna-pre-amp and 10512A lead-in cable, \$1,150.00.
Prices f.o.b. factory.
Data subject to change without notice.

TUNABLE VLF COMPARATOR

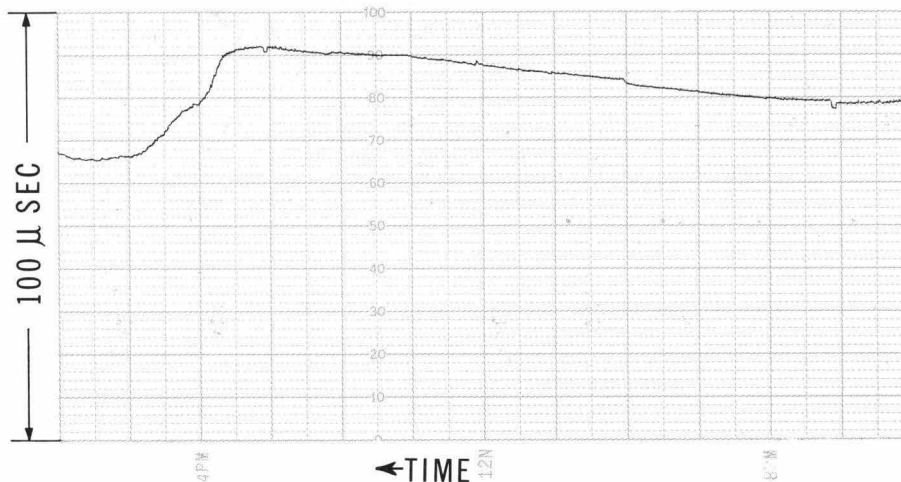

Trace made by Dymec tunable VLF Comparator while checking quartz oscillator against Navy station NBA (24 kc) in Panama (3300-mile path). Chart scale is 100 μ sec phase difference edge to edge. Slope of 2 μ sec/hr between 8 A.M. and

1 P.M. shows oscillator frequency offset of 5.5 parts in 10^{10} . Change occurring at 4:30 P.M., characteristic of all VLF transmissions, is diurnal shift caused by night-time ionosphere changes.

For frequency comparisons that must be made over distances in excess of 2000 miles, VLF transmissions in the 14-30 kc band are advantageous because of their reliable reception and phase stability at long ranges. What is more, this frequency range makes available several different transmissions offered by the U. S. Navy, the National Bureau of Standards, and the British Post Office for comparison work, providing coverage over most of the earth's surface. For this purpose, the Dymec Division of Hewlett-Packard has designed a tunable VLF Comparator that tunes in 100-cps steps from 14 to 30 kc. The Comparator can be quickly changed to another channel in case a particular transmission becomes unusable because of propagation changes or because of intermittent scheduling. It works with VLF stations up to 6000 miles distant.

The Dymec tunable VLF Comparator plots the phase difference between the received signal and local standard oscillator in much the same manner as the -hp- 117A VLF Phase Comparator described in this issue. The techniques for deriving the phase difference, however, are entirely different in order to permit tuning.

The tunable VLF Comparator uses frequency synthesis techniques to translate the 100-kc local standard signal to the same frequency to which the instrument is tuned and then processes the synthesized and received signals through identical IF channels to the phase comparator. The voltage output of the phase comparator controls a servo-driven phase-shifter that phase-shifts the reference 100-kc signal from the external frequency standard to maintain the received and synthesized

signals in phase. The built-in recorder plots the position of the phase-shifter to provide the record of phase difference. The accumulated phase difference is also displayed on a digital readout. In addition, the instrument has an IF output and a monitor loudspeaker for telegraphic communications and for time-tick synchronization of clocks.

The tunable VLF Comparator has high sensitivity (0.1 μ v) and operates in the presence of strong interfering signals or noisy environments, making it well suited for use with mobile or shipborne frequency standards. The completely transistorized instrument operates from ac line power or it can operate with batteries (24-30 v) with optional spring-driven chart drives.

—Albert Benjaminson and
Cleaborn Riggins

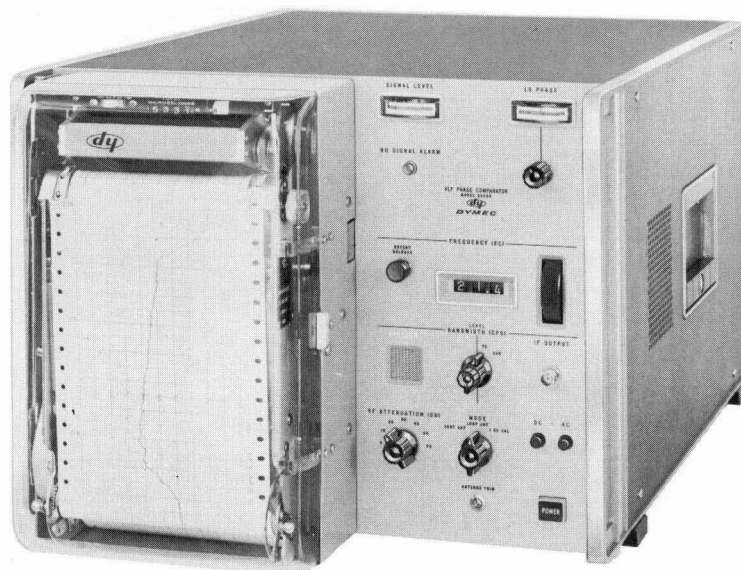

BRIEF SPECIFICATIONS
DYMEC
MODEL DY-2365B
VLF PHASE COMPARATOR

FREQUENCY RANGE: 14.0 to 30.0 kc in 100 cps steps.
SIGNAL LEVEL RANGE: 100 db with switched attenuator (60 db in 10-db steps) and agc (40 db at input compressed to 6 db at IF).
IF SELECTIVITY: At least 15 db rejection of adjacent channel (100 cps from selected channel); tolerates additional 15 db of interference without affecting phase tracking (on phase \times 1).
SERVO TIME-CONSTANT: 30 to 60 seconds.
IF CARRIER OUTPUT: 3.1 kc, 0 to 1 v into 600 ohm. Bandwidth selected by front panel switch, 75 or 200 cps.
POWER REQUIRED: 115 or 230 v \pm 10%, 60 cps, 40 watts.
 24 to 30 v dc, 0.7 amp (spring-driven chart drive needed for battery operation).
PRICE: Model DY-2365B VLF Phase Comparator (without antenna): \$4975.00.

DYMEC DIVISION
HEWLETT-PACKARD CO.
 275 Page Mill Road, Palo Alto, Calif.
 Prices f.o.b. Palo Alto, Calif.
 Data subject to change without notice.